

LOCKABLE BOX HANDLE /w LOCK TAB (SEALED BOX HANDLE OPTION AVAILABLE UPON REQUEST)

PLAN VIEW
SCALE 1:15

SPECIFICATIONS:

- FRAME TO BE 6061-T6 ALUMINUM ALLOY
- TOP COVER PLATE TO BE 6mm ALUMINUM CHECKER PLATE, TYPE 5086
- ALL HARDWARE TO BE STAINLESS STEEL (INCLUDED)
- ALL ALUMINUM SURFACES IN CONTACT WITH CONCRETE TO HAVE 2 COATS OF BITUMATISTIC PAINT.

INSTALLATION GUIDELINES:

1. LOWER TOP COVER INTO PLACE AND CENTER IN OPENING
2. MARK LOCATION OF ANCHORS ON CONCRETE WALL
3. REMOVE TOP COVER AND DRILL ANCHOR HOLES
4. REPLACE TOP COVER AND SECURE WITH WEDGE ANHORS (PROVIDED)

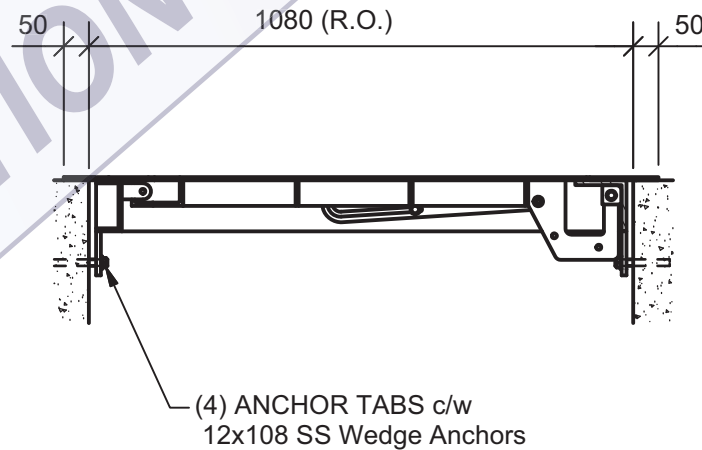

SECTION 1
SCALE 1:15

DIMENSION ARE MILLIMETERS UNLESS OTHERWISE NOTED **M**ETRIC

THIS DRAWING IS THE PROPERTY OF CDM MECHANICAL LTD. THE CONTENTS ARE CONFIDENTIAL AND ARE NOT TO BE DISCLOSED OR REPRODUCED WITHOUT THE WRITTEN CONSENT OF CDM AND ARE NOT TO BE USED IN ANY WAY DETRIMENTAL TO ITS INTERESTS. COPYRIGHT

CLIENT:

Contractor



CDM Mechanical Ltd.
www.cdmmechanical.com

1	Feb 23/18	For Information	DAA	
REV	DATE	DESCRIPTION	ISSUED BY	APP'D
PROJECT:		Project Location		
DRAWING:		750 x 900 Aluminum Access Hatch, Standard Drop-In /w Ribs MODEL: CDM-HTA-0750x0900s-AL		
DATE:	DRAWN:	DESIGN:	SCALE:	JOB No:
NOV/17	DAA		AS NOTED	###-501
DRAWING No:				HTA01