

**ELEVATION**  
SCALE 1:15

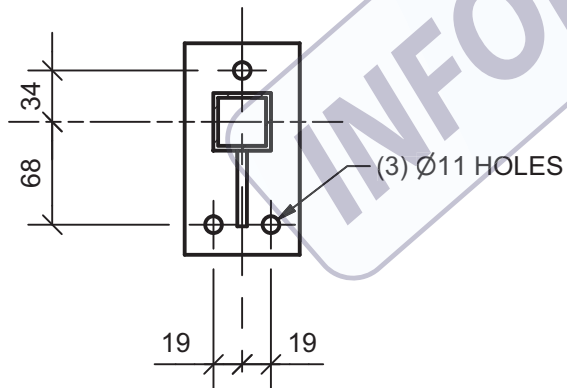
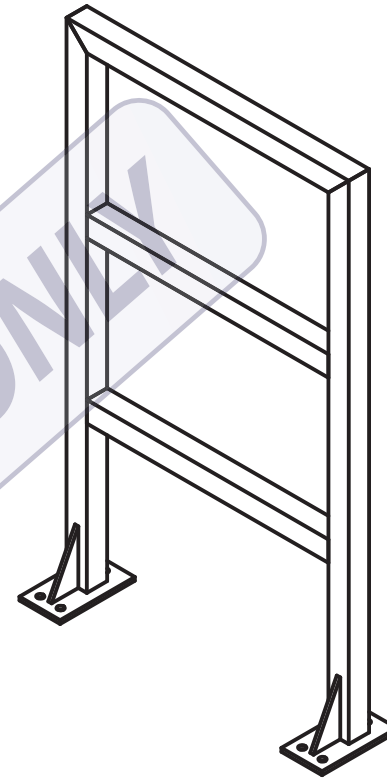

**BOLT HOLE PATTERN**  
SCALE 1:5

**SPECIFICATIONS:**  
- MATERIAL: STAINLESS STEEL, GRADE 304

DIMENSION ARE MILLIMETERS  
UNLESS OTHERWISE NOTED

THIS DRAWING IS THE PROPERTY OF  
CDM MECHANICAL LTD. THE  
CONTENTS ARE CONFIDENTIAL AND  
ARE NOT TO BE DISCLOSED OR  
REPRODUCED WITHOUT THE WRITTEN  
CONSENT OF CDM AND ARE NOT TO  
BE USED IN ANY WAY DETRIMENTAL  
TO ITS INTERESTS.  
COPYRIGHT

CLIENT:

Contractor



*CDM Mechanical Ltd.*  
www.cdmmechanical.com

REV	DATE	DESCRIPTION	ISSUED BY	APP'D
1	Jun 3/19	For Information	DAA	
PROJECT:		Project Location		
DRAWING:		Safety Grab Rail (450 wide) - Stainless Steel STOCK No: CDM-GR-450-SS		
DATE:	DRAWN:	DESIGN:	SCALE:	JOB No:
Jun/19	DAA		AS NOTED	###-554
DRAWING No:				GR01